

Tomco Techtips

TM

ISSUE 28

INTEGRATED EGR VALVES

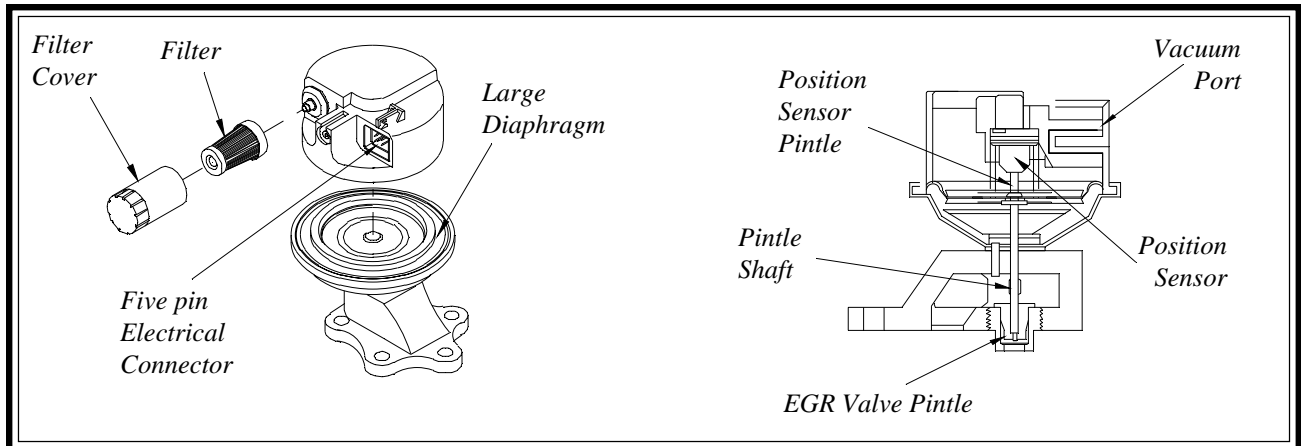

Figure 1

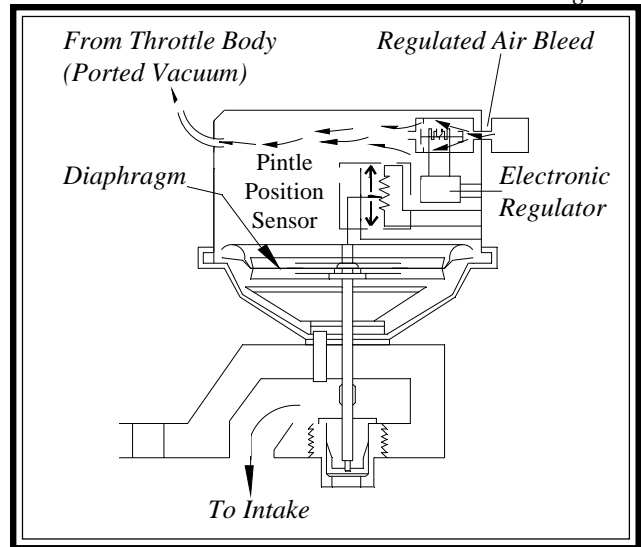

Figure 2

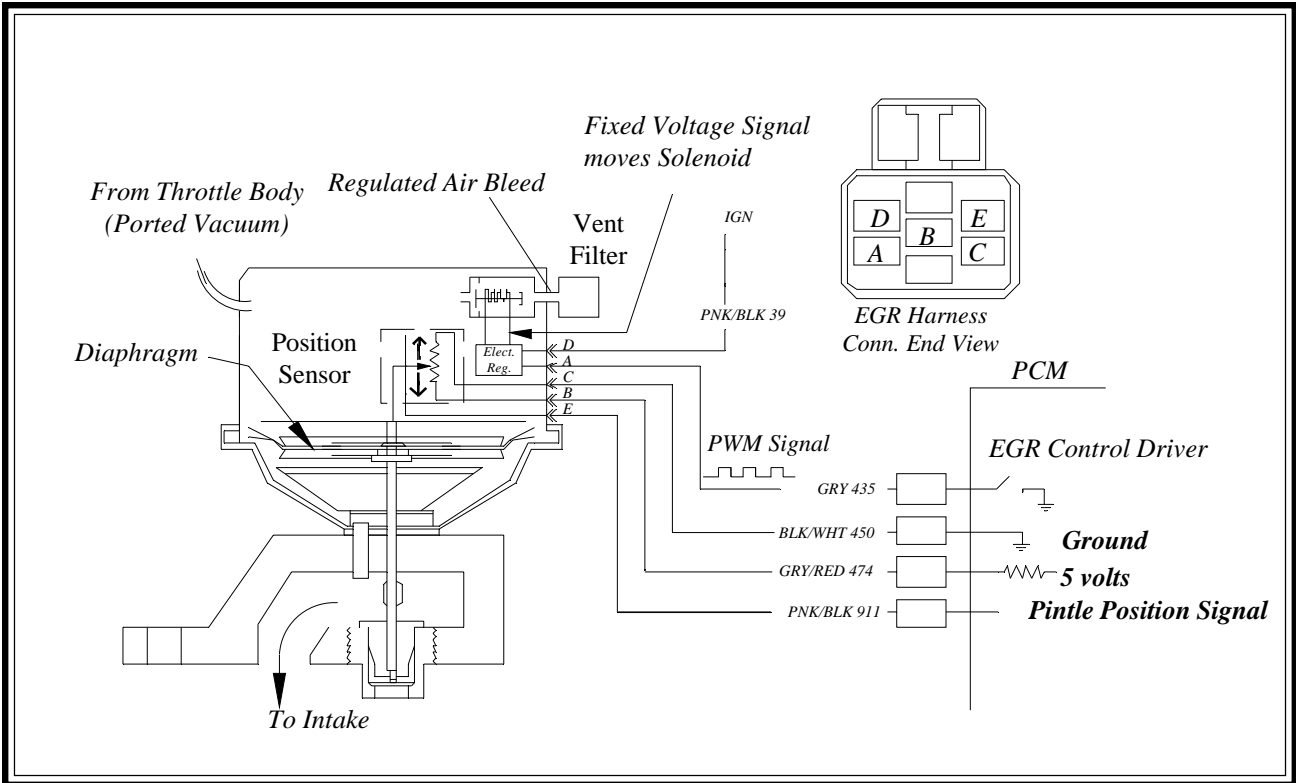

Figure 3

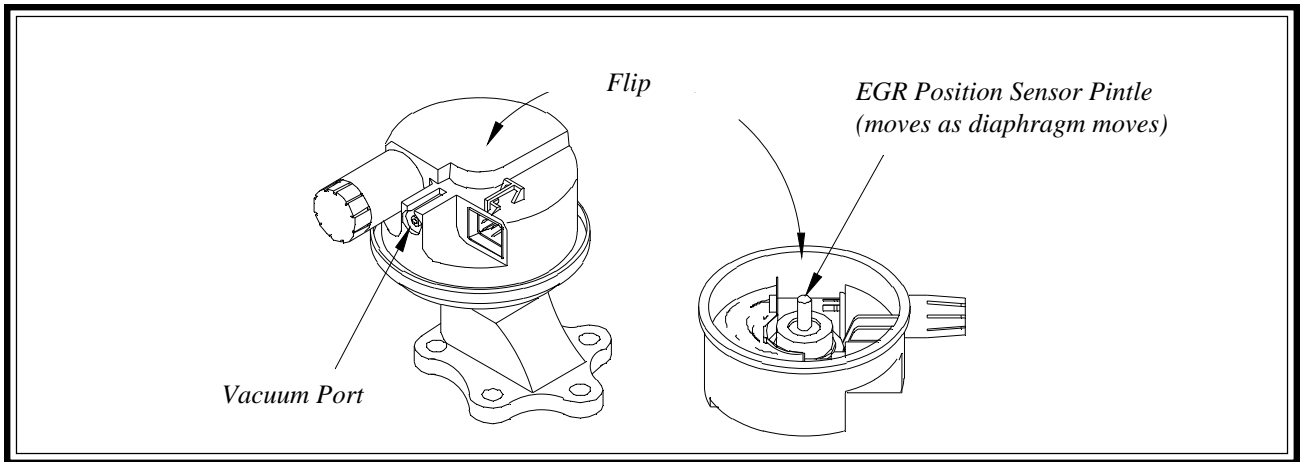

Figure 4

Testing the Position Sensor

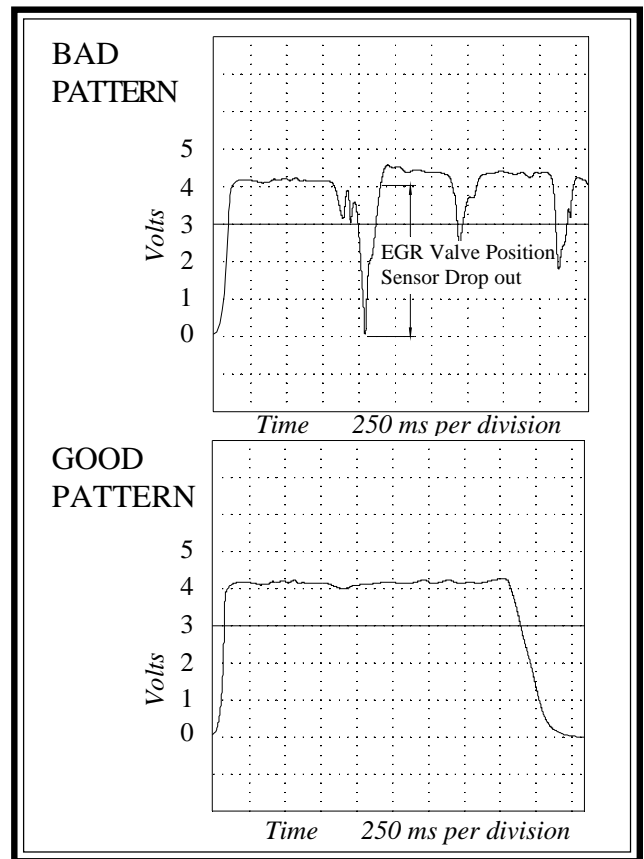

Figure 5

Testing the EVR

Electronics 101: Voltage Drops

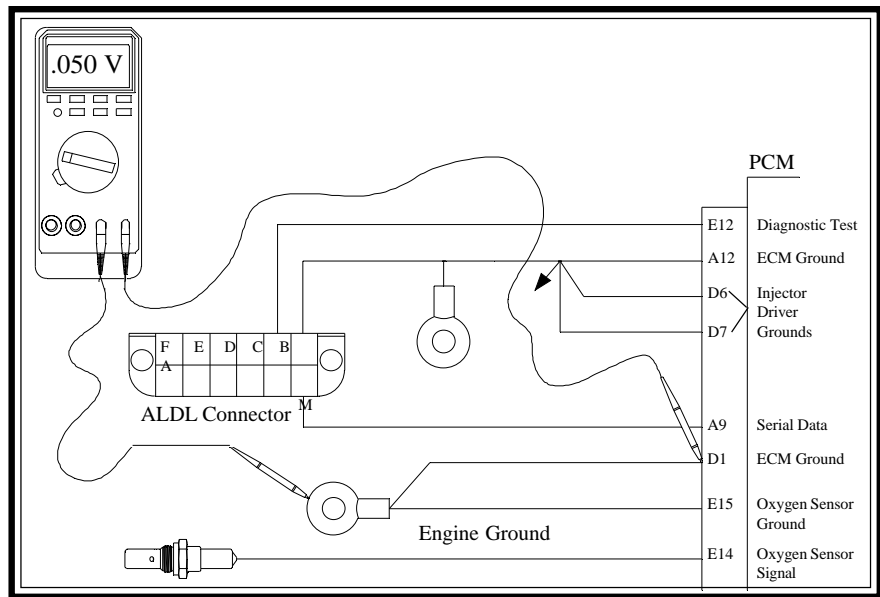

Figure 6

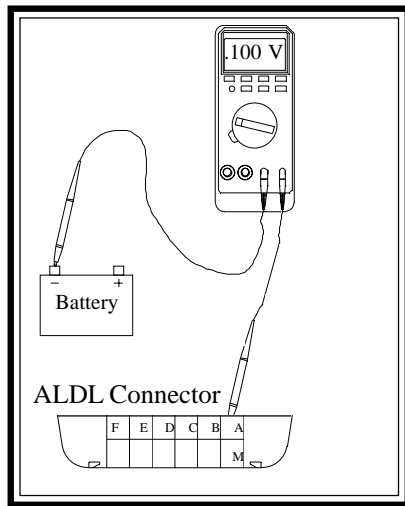

Figure 7

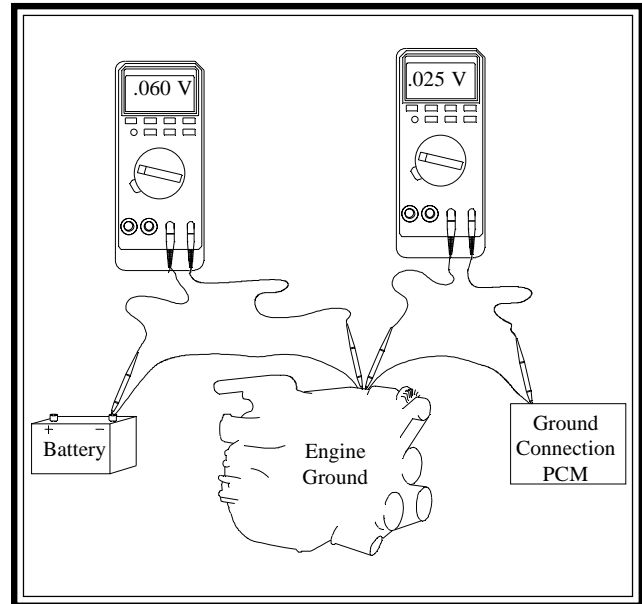

Figure 8