

THROTTLE HOLDING SOLENOIDS

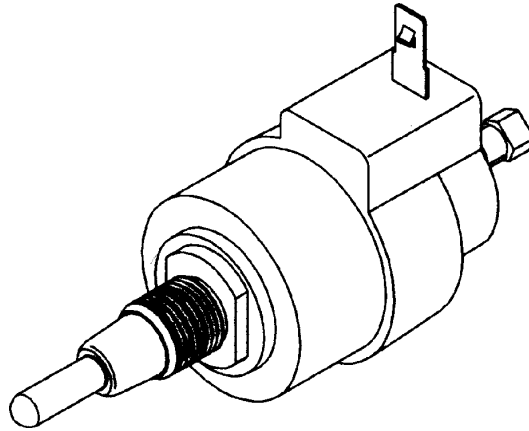

WHAT THEY DO

Control idle during various load conditions.

FAILURE SYMPTOMS

Improper idle or dieseling.

MAINTENANCE/SERVICE

Check during tune-up or idle problem.
Adjust / replace if not functioning correctly.

YEAR	ENGINE	MODEL	MFG	PART #
------	--------	-------	-----	--------

AMC

4 cyl.

1982-80	2.5L (B) 151"	All	R-2	8130
1979-77	All	All (w/A/T, CA)	H-2	8111

6 cyl.

1983	4.2L (B) 258"	All	C-2	8111
1980-76	All	All (w/A/T)	C-2	8111
1979-76	All	All (incl. CA)	C-1	8111
1975-74	All	All (w/A/T, CA)	C-1	8107

8 cyl.

1979-73	All	All (w/A/T)	F-2	8107
1974-73	All	All (w/A/T)	F-4	8107

BUICK

4 cyl.

1982-80	2.5L (5) 151"	Century, Skylark	R-2	8130
---------	---------------	------------------	-----	------

6 cyl.

1983-80	2.8L (X,Z,7) 173"	Skylark	R-2	8130
1978	3.2L (C) 196"	All	R-2	8116

THROTTLE HOLDING SOLENOIDS

YEAR	ENGINE	MODEL	MFG	PART #
BUICK 6 cyl (Contd)				
1978-75	3.8L (A,C,2) 231"	All	R-2	8116
1975-73	4.1L (D) 250"	All (incl. Apollo)	R-1	8110
8 cyl.				
1978-77	5.0L (Y) 301"	Century, Regal, Skylark	R-2	8116
1978-77	5.0L (U) 305"	Century, Regal, Skylark	R-2, 4	8116
1979-75	5.7L (J,L,R,X) 350"	All	R-4	8119
1978-77	5.7L (H,L,R,X) 350"	Century, Regal, Skylark	R-2, 4	8116
1979-78	6.6L (K) 403"	All	R-4	8119
1978	6.6L (Z) 400"	Century, Regal	R-2, 4	8116
1976-75	7.5L (T) 455"	All	R-4	8119
1972	All	All (V-8)	R-2, 4	8116

CADILLAC

6 cyl.				
1983-82	4.1L (4) 252"	All	R-4	8119
8 cyl.				
1980	6.0L (6) 368"	All (exc. EFI)	R-4	8119
1974-71	All	All	R-4	8111

CHECKER MOTORS

6 cyl.				
1972	4.1L (D) 250"	All	R-1	8110

CHEVROLET

4 cyl.				
1977-76	1.4L (I) 85"	All (w/A/T, incl. Hi-Alt, CA)	R-1	8110
1978-76	1.6L (E,J) 98"	All (w/A/T, incl. Hi-Alt, CA)	R-1	8110
1976	2.3L (A) 140"	All (w/A/T, incl. Hi-Alt, CA)	R-1	8110
1975-73	2.3L (A) 140"	All	R-1	8110
1974-71	2.3L (B) 140"	All (w/2nd Design)	R-2	8116
1983-80	2.5L (V,5) 151"	Camaro, Citation (incl. Canada, Exp)	R-2	8130
6 cyl.				
1983-80	2.8L (X,Z,1,7) 173"	Camaro, Celebrity, Citation	R-2	8130
1978	3.2L (C) 196"	All	R-2	8116
1978	3.3L (M) 200"	All	R-2	8116
1978	3.8L (A) 231"	All	R-2	8116
1979-77	4.1L (D) 250"	All	R-1	8110
1976-74	4.1L (D) 250"	All (w/A/T, exc. Int. Cyl. Head)	R-1	8110
8 cyl.				
1978-76	5.0L (Q,U) 305"	Monza (w/A/T)	R-2	8116
1977-76	5.0L (Q,U) 305"	All	R-2	8116
1973-72	5.0L (F) 307"	All	R-2	8116
1979-78	5.7L (H,L,4) 350"	Camaro (w/A/T, incl. CA, w/Carb 17058232, 530)	R-4	8119
1978-77	5.7L (H,L,X,4) 350"	All (exc. Carb 17058232, 530)	R-4	8132
1977-72	5.7L (H,J,K,L,T) 350"	Corvette	R-4	8116
1976-72	6.6L (R,U) 400"	All	R-2, 4	8116
1974-72	6.6L (S) 402"	All	R-4	8116

THROTTLE HOLDING SOLENOIDS

YEAR	ENGINE	MODEL	MFG	PART #
CHEVROLET 8 cyl (Contd)				
1972	7.4L (V,W) 454"	Corvette	R-4	8116

CHEVROLET TRUCK

6 cyl.

1982	2.8L (B) 173"	Series 10	R-2	8130
1978	3.8L (A) 231"	El Camino	R-2	8116
1980-79	4.1L (D) 250"	All Series	R-2	8129
1978-73	4.1L (D,Q) 250"	Series 10, 30, 50, 60	R-1	8110
1975-74	4.1L (D,Q) 250"	Blazer	R-1	8116
1980-73	4.8L (T) 292"	Series 10, 30, 50, 60	R-1	8110
1975-74	4.8L (T) 292"	Blazer	R-1	8116
1972	All	Series 10-30 (exc. C.E.C.)	R-1	8116

8 cyl.

1974-73	5.0L (X) 307"	All Series (All/T)	R-2	8110
1974-72	5.0L (X) 307"	Series 10-30	R-2	8116
1978-77	5.7L (L) 350"	Series 10-30	R-4	8132
1975-73	5.7L (V) 350"	All Series (All/T)	R-2	8110
1975-72	5.7L (V,Y) 350"	Series 10, 30	R-2, 4	8116
1982-79	6.0L (B) 366"	School Bus Chassis	R-1	8116
1974	6.6L (M) 400"	El Camino	R-4	8116
1972	6.6L 402"	20, 30 Series	R-4	8116
1982-79	7.0L (E) 427"	School Bus Chassis	R-2	8116

CHRYSLER

8 cyl.

1977-75	5.2L (G) 318"	All	C-2	8111
1981-80	5.9L (J) 360"	All (incl. Mexico)	C-4	8107
1977-74	6.6L (N) 400"	All (w/A/T, incl. Exp, HP)	C-4	8107
1977-72	7.2L (T,U) 440"	All (w/A/T, incl. Exp, HP)	C-4	8107

DODGE

6 cyl.

1982-80	3.7L (D,G,H) 225"	All (incl. Canada, Exp, Mexico)	C-2	8111
---------	-------------------	---------------------------------	-----	------

8 cyl.

1977-75	5.2L (G) 318"	All	C-2	8111
1973-72	5.6L (H) 340"	All (w/A/T, incl. Exp, HP)	C-4	8107
1980	5.9L (J,L) 360"	All (incl. Mexico)	C-4	8107
1977-72	5.9L (K) 360"	All (w/A/T, incl. Exp, HP)	C-4	8107
1977-72	6.6L (N,P) 400"	All (w/A/T, incl. Exp, HP)	C-4	8107
1977-72	7.2L (T,U) 440"	All (w/A/T, incl. Exp, HP)	C-4	8107

THROTTLE HOLDING SOLENOIDS

YEAR	ENGINE	MODEL	MFG	PART #
------	--------	-------	-----	--------

DODGE TRUCK

6 cyl.

1974-73	3.7L (B) 225"	All Series (w/A/T) 100-300	C-2	8107
---------	---------------	----------------------------	-----	------

8 cyl.

1977-75	5.2L (E) 318"	Conventional Cab (incl. 4WD), Compact Models, Ramcharger (incl. CA) BBD 8024,25,85-S	C-2	8111
---------	---------------	--	-----	------

FORD

4 cyl.

1973	1.6L (W) 98"	Pinto	C-1	8107
------	--------------	-------	-----	------

6 cyl.

1978-77	2.8L (Z) 171"	Mustang, Pinto	F-2	8111
1972-70	2.8L (U) 170"	All	C-1	8107
1980-74	3.3L (B,T) 200"	Granada, Maverick	C-1	8111
1974-70	3.3L (T) 200"	All	C-1	8107
1983-82	3.8L (3) 232"	Granada, LTD, Mustang, T-Bird	F-2	8107
1972-70	3.9L (V) 240"	All	C-1	8107
1969	3.9L (V) 240"	All (w/M/T)	F-1	8107
1980-74	4.1L (C,L) 250"	Granada, Maverick	C-1	8111
1979-78	4.1L (L) 250"	All (incl. CA)	C-1	8150
1978-77	4.1L (L) 250"	Granada	C-1	8107
1974-70	4.1L (L) 250"	All	C-1	8107
1969	4.1L (L) 250"	All (w/M/T)	F-1	8107

8 cyl.

1968-67	4.7L (A,C) 289"	All	F-4	8107
1980-70	5.0L (D,F) 302"	All (incl. CA, Canada)	F-2	8107
1978-77	5.0L (F) 302"	Granada, Mustang II after 6-27-77 (w/A/T, incl. CA)	F-2	8111
1974-67	5.0L (D,F) 302"	All	F-4	8107
1980-70	5.8L (G,H,Q) 351"	All (w/M, W, incl. CA, Canada)	F-2	8107
1974-67	5.8L (H) 351"	All	F-4	8107
1971-70	6.4L (Y) 390"	All (incl. CA, Canada)	F-2	8107
1969-67	6.4L (H,S,X,Y,Z) 390"	All	F-4	8107
1978-71	6.6L (S) 400"	All (incl. CA, Canada)	F-2	8107
1973-68	7.0L (C,J,N,P,Z) 429"	All	F-4	8107
1972-70	7.0L (K) 429"	All (incl. CA, Canada)	F-2	8107
1970-67	7.0L (P,Q,R) 428"	All	F-4	8107
1968-67	7.0L (R) 427"	All	F-4	8107
1974	7.5L (A,C) 460"	All (w/A/T, incl. CA)	C-4	8111
1974-72	7.5L (A,C) 460"	All	F-4	8107

FORD TRUCK

6 cyl.

1974	3.9L (A) 240"	E & F100, 200, 300	C-1	8111
1973	3.9L (A) 240"	F100	C-1	8107
1981-75	4.9L (B,C) 300"	F150/350, B600, C600, F600 (All/T)	C-1	8150
1980-79	4.9L (B,E) 300"	F100/250 (w/A/T)	C-1	8111

8 cyl.

1980-70	5.0L (F,G) 302"	All	F-2	8107
---------	-----------------	-----	-----	------

THROTTLE HOLDING SOLENOIDS

YEAR	ENGINE	MODEL	MFG	PART #
FORD TRUCK 8 cyl (Contd)				
1980-75	5.8L (G,H) 351"	All (w/M, W Engine)	F-2	8107
1976-70	5.9L (Y) 360"	All	F-2	8107
1976-70	6.4L (H) 390"	All	F-2	8107
1980-77	6.6L (S,Z) 400"	All	F-2	8107
1975-73	7.5L (A,J) 460"	F100/350, F150/350, F250/350, M450/500	F-4	8107

GMC TRUCK

6 cyl.

1982	2.8L (B) 173"	Series 10	R-2	8130
1980-79	4.1L (D) 250"	All Series	R-1	8129
1980-73	4.1L (D) 250"	All Series	R-1	8110
1975-74	4.1L (D,Q) 250"	Jimmy	R-1	8116
1980-73	4.8L (T) 292"	All Series	R-1	8110
1975-74	4.8L (T) 292"	Jimmy	R-1	8116
1972	All	Series 15-35 (exc. C.E.C.)	R-1	8116

8 cyl.

1974-73	5.0L (X) 307"	All Series (All/T)	R-2	8110
1974-72	5.0L (X) 307"	All Series	R-2	8116
1978-77	5.7L (L) 350"	Series 15-35	R-4	8132
1975-73	5.7L (V) 350"	All Series (All/T)	R-2	8110
1975-72	5.7L (V,Y) 350"	All Series	R-2, 4	8116
1982-79	6.0L (B) 366"	School Bus Chassis	R-1	8116
1977	6.6L (K) 403"	Motor Home (w/A/T, exc. CA)	R-4	8116
1974	6.6L (M) 400"	Sprint	R-4	8116
1982-79	7.0L (E) 427"	School Bus Chassis	R-1	8116

IHC TRUCK

8 cyl.

1973	5.0L 304"	Lt. Duty (incl. CA)	H-2	8107
1974	5.7L 345"	Scout Traveall	C-4	8107
1973	5.7L 345"	Lt. Duty (incl. CA)	H-2	8107
1974	6.4L 392"	Scout Traveall	C-4	8107

JEEP

4 cyl.

1986-81	2.5L (B) 151"	CJ (All/T)	R-2	8130
---------	---------------	------------	-----	------

6 cyl.

1986-79	4.2L (C) 258"	CJ5, CJ7, MPV, Cherokee, J-10 (w/BBD 8185,187,195,8216, 236,246,253,256,257,278,8302,303,306,307,308,309,311, 312,313,333,335,336,337,338,339,340,341,349,351,354, 355,357,363,366,372)	C-2	8111
1982-80	4.2L (C) 258"	CJ5, CJ7, MPV (All/T)	C-2	8107
1978-76	All	All (incl. CA)	C-1	8111

8 cyl.

1981-75	5.0L (H) 304"	CJ7, Cherokee, J-10, J-20, Wagoneer (w/2150 Carb)	F-2	8107
1986-75	5.9L (N) 360"	CJ7, Cherokee, J-10, J-20, Wagoneer (w/2150 Carb)	F-2	8107
1974	All	All	F-4	8107

THROTTLE HOLDING SOLENOIDS

YEAR	ENGINE	MODEL	MFG	PART #
LINCOLN				
8 cyl.				
1977	6.6L (S) 400"	Continental, Mark (w/A/T, incl. Hi-Alt, CA)	F-2	8107
1974	7.5L (A,C) 460"	Continental, Mark (w/T/E)	C-4	8111
1973-72	7.5L (A,C) 460"	Continental, Mark	F-4	8107

MERCURY

6 cyl.				
1978-77	2.8L (Z) 171"	Bobcat	F-2	8111
1972-71	2.8L (U) 170"	All	C-1	8107
1980-74	3.3L (B,T) 200"	Comet, Monarch	C-1	8111
1974-70	3.3L (T) 200"	All	C-1	8107
1983-82	3.8L (3) 232"	Capri, Cougar, Marquis	F-2	8107
1969	3.9L (V) 240"	All (w/M/T)	F-1	8107
1980-74	4.1L (C,L) 250"	Comet, Monarch	C-1	8111
1979-78	4.1L (L) 250"	All (incl. CA)	C-1	8150
1978-77	4.1L (L) 250"	All	C-1	8107
1974-70	4.1L (L) 250"	All	C-1	8107
1969	4.1L 250"	All (w/M/T)	F-1	8107
8 cyl.				
1968-67	4.7L (A,C) 289"	All	F-4	8107
1980-70	5.0L (D,F) 302"	All (incl. CA, Canada)	F-2	8107
1978-77	5.0L (F) 302"	All (w/A/T, incl. CA, after 6-27-77)	F-2	8111
1974-67	5.0L (D,F) 302"	All	F-4	8107
1980-70	5.8L (G,H,Q) 351"	All (w/M, W, incl. CA, Canada)	F-2	8107
1974-67	5.8L (H) 351"	All	F-4	8107
1971-70	6.4L (Y) 390"	All (incl. CA, Canada)	F-2	8107
1969-67	6.4L (H,S,X,Y,Z) 390"	All	F-4	8107
1978-71	6.6L (S) 400"	All (incl. CA, Canada)	F-2	8107
1973-68	7.0L (C,J,N,P,Z) 429"	All	F-4	8107
1972-70	7.0L (K) 429"	All (incl. CA, Canada)	F-2	8107
1970-67	7.0L (P,Q,R) 428"	All	F-4	8107
1968-67	7.0L (R,W) 427"	All	F-4	8107
1974	7.5L (A,C) 460"	All (w/A/T, incl. CA)	C-4	8111
1974-72	7.5L (A,C) 460"	All	F-4	8107

OLDSMOBILE

4 cyl.				
1982-80	2.5L (V,5) 151"	Cutlass Ciera, Omega (incl. Canada, Exp)	R-2	8130
6 cyl.				
1982-80	2.8L (X,Z,7) 173"	Omega	R-2	8130
1978-75	3.8L (A,C) 231"	All	R-2	8116
1975-73	4.1L (D) 250"	All	R-1	8110
8 cyl.				
1979-78	4.3L (F) 260"	All	R-2	8119
1978-77	5.0L (U) 305"	Delta 88, Omega, Starfire	R-2	8116
1979-75	5.7L (J,K,L,R,X) 350"	All (incl. CA)	R-4	8119
1978	5.7L (G) 350"	Delta 88, Omega, Starfire	R-2	8116
1977-75	5.7L (J,K,L,R,X) 350"	All	R-4	8119

THROTTLE HOLDING SOLENOIDS

YEAR	ENGINE	MODEL	MFG	PART #
OLDSMOBILE 8 cyl (Contd)				
1974-72	5.7L (K,M) 350"	All	R-4	8116
1979-77	6.6L (K) 403"	All (incl. CA)	R-4	8119
1977	6.6L (K) 403"	All	R-4	8119
1976-75	7.5L (S,T) 455"	All (incl. CA)	R-4	8119
1976-75	7.5L (W) 455"	All	R-4	8119
1974-72	7.5L (W,X,Y) 455"	All	R-4	8116

PLYMOUTH

6 cyl.

1980	3.7L (D) 225"	All (incl. Canada, Exp, Mexico)	C-2	8111
------	---------------	---------------------------------	-----	------

8 cyl.

1977-75	5.2L (G) 318"	All	C-2	8111
1973-72	5.6L (H) 340"	All (w/A/T, incl. Exp, HP)	C-4	8107
1977-74	5.9L (L) 360"	All (w/A/T, incl. Exp, HP)	C-4	8107
1977-72	6.6L (N,P) 400"	All (w/A/T, incl. Exp, HP)	C-4	8107
1977-72	7.2L (T,U) 440"	All (w/A/T, incl. Exp, HP)	C-4	8107

PONTIAC

4 cyl.

1975	2.3L (A) 140"	All	R-1	8110
1983-80	2.5L (F,S,V,5) 151"	Firebird, Phoenix (incl. Canada, Exp)	R-2	8130

6 cyl.

1983-80	2.8L (X,Z,7) 173"	Firebird, Phoenix, 6000	R-2	8130
1978-76	3.8L (A,C) 231"	All	R-2	8116
1976-72	4.1L (D) 250"	All	R-1	8110

8 cyl.

1975	4.3L (F) 260"	All	R-2	8119
1979-78	4.9L (W) 301"	All	R-4	8116
1978-77	5.0L (U) 305"	All	R-2	8116
1972	5.0L (F) 307"	Ventura	R-2	8116
1979-75	5.7L (H,J,L,P,R,X) 350"	All	R-4	8116
1979-77	6.6L (K) 403"	All	R-4	8116
1979-75	6.6L (S,Z) 400"	All	R-4	8116
1975	7.5L (W) 455"	ALL (incl. CA)	R-4	8116

WHITE TRUCK

1973	3.3L 200"	All	H-4	8107
1973	3.8L 235"	All	H-4	8107
1973	4.1L 250"	All	H-4	8107

THROTTLE HOLDING SOLENOIDS

OEM INTERCHANGE

OEM#	PART#	OEM#	PART#	OEM#	PART#	OEM#	PART#		
	AMC	4026204	8111	D4DZ-9D856A	8111	17068095	8130	7040316	8110
8120480	8107	4026205	8111	D4PZ-9D856A	8111	17078752	8130	7043575	8110
8127321	8111	4026210	8107	D7PZ-9D856B	8111	1997162	8116	7043619	8119
8127629	8111	4026211	8107	D7ZZ-9D856A	8111	1997403	8116	7043620	8119
8132738	8130	4049343	8111			1997409	8116	7044300	8116
8133480	8130	4186224	8111	GENERAL MOTORS		1997416	8116		
				1114450	8116	1997417	8116	ROCHESTER	
	CARTER	FORD		1114452	8116	1997424	8116	1498570	8111
213-53S	8107	D0AZ-9D856A	8107	1498570	8111	1997461	8132	1604093	8111
		D1AZ-9D856C	8107	1604093	8111	1997464	8116		
	CHRYSLER	D2AF-9D856EA	8107	17052388	8116	1997470	8116		
3856858	8107	D2AF-9D856FA	8107	17060708	8130	525611	8116		
3879845	8107	D3AZ-9D856A	8107	17061814	8130	547681	8116		
4026203	8111	D4AZ-9D856B	8111	17067425	8130	7030735	8116		

NUMERICAL LIST

PART#	MFG	APPLICATION & YEAR	PART#	MFG	APPLICATION & YEAR
8107	C-1,F-1,2,4	AMC 73-79, CHRY 72-77,80-81, DODGE 72-77,80, D TRK, IHC 73-74, FORD 67-80, 82-83, F TRK 70-80, JEEP 74-86, LINC 72-73,77, MERC 67-80,82-83, PLY 72-77, WHT TRK 73	8116	R-1,2,4	BUICK 72,75-78, CHEV 71-78, C TRK 72-75, 78-82, GMC TRK 72-75,79-82, OLDS 72-78, PONT 72,75-79
8110	R-1	BUICK, OLDS 73-75, CHECKER MOTORS 72, CHEV 73-79, C TRK, GMC TRK 73-80, PONT 72-76	8119	R-4	BUICK, OLDS 75-79, CAD 80,82-83, CHEV 78-79, OLDS 75-79, PONT 75
8111	C-1,2,F-2, H-2,R-4	AMC 76-80,83, CAD 71-74, CHRY, DODGE, D TRK 75-77, FORD 74-80, F TRK 74,79-80, JEEP 76-86, LINC 74, MERC 74-80, PLY 75-77,80	8130	R-2	AMC, OLDS 80-82, BUICK, CHEV, PONT 80-83, C TRK, GMC TRK 82, JEEP 81-86
			8132	R-2,4	CHEV, C TRK, GMC 77-78, FORD, MERC 78-79, F TRK 75-81