

# REPLACEMENT FUEL BOWL

## CARTER THERMOQUAD

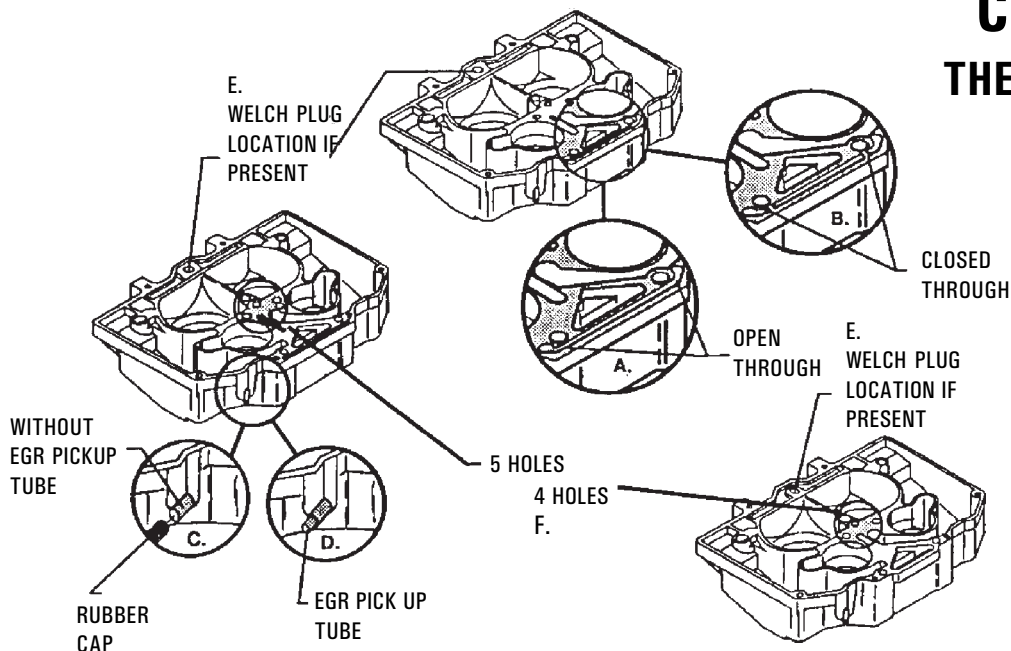

### Ordering Instructions

**A. If carburetor tag number is available, use interchange to correctly identify correct fuel bowl number.**  
**B. If carburetor tag number is NOT available, use the following visual identification procedure to obtain a fuel bowl reference number. Then cross the reference number to a Tomco part number.**

- Determine if you have an OPEN through (Example A) or a CLOSE through (Example B).

First letter of part number prefix: "O" = OPEN or "C" = CLOSED

- Determine if your unit has an EGR pick-up tube (Example D) or no EGR pick-up tube (Example C). The EGR tube will be a brass tube inside the fuel bowl tube as shown in Example D.

Second letter of part number prefix: "T" = EGR pick-up tube or "O" = NO EGR pick-up tube

- Measure diameter of primary bores to determine if you have a large (1 1/2") or small (1 3/8") bore body. Note: Take this measurement on the throttle body side of fuel bowl.

- Base part number is determined by bore size: Large (1 1/2") = 2869 Small (1 3/8") = 2597

- First letter of the suffix: (Example C) "C" = Rubber tube cap (for units without EGR tube). If EGR tube is present, no letter needed.

- Second letter of suffix: In back of fuel bowl (see example E), see if a welch plug is in your unit. If so, put a "P" on the end of the part number. If NO welch plug, no letter is needed.

- In the center of the fuel bowl, between the primary and secondary bores (Example F), most units have four (4) drilled holes. Should your unit have five (5) drilled holes, put a "-1" after the base part number, i.e. CO-2869-1CP

Fuel Bowl Ref. No.	Tomco No.	Fuel Bowl Ref. No.	Tomco No.
CO-2869-C	8600	CO-2597-C	8607
CO-2869-1CP	8601	CT-2597	8608
CT-2869	8602	OO-2597-C	8609
OO-2869-C	8603	OO-2597-CP	8610
OO-2869-CP	8604	OT-2597	8611
OT-2869	8605	OT-2597-P	8612
OT-2869-P	8606		

#### Fuel Bowl Reference Number Example:

OT-2597-P

"O" = Open trough  
 "T" = Has EGR tube  
 2597 = Small bore (1 3/8")  
 = No rubber cap needed, has EGR tube  
 "P" = Has welch plug

CO-2869-1CP

"C" = Closed trough  
 "O" = NO EGR tube  
 2869 = Large bore (1 1/2")  
 -1 = 5 drilled holes  
 "P" = Welch plug

CARB#	KIT#	TB#	FLOAT#	PART #	CARB#	KIT#	TB#	FLOAT#	PART #
6090	5258B	0-2799	705	8600	6342	5258B	0-2799	705	8600
6138	5258B	0-2533	705	8607	6394	5258B	0-2533	705	8607
6139	5258B	0-2533	705	8607	6410	5258B	0-2445	705	8602
6140	5258B	0-2799	705	8600	6411	5258B	0-2799	705	8600
6165	5258B	0-2799	705	8600	6446	5258B	0-2799	705	8600
6166	5258B	0-2799	705	8600	6452	5258B	0-2798	705	8600
6318	5258B	0-2533	705	8607	6453	5258B	0-2798	705	8600
6319	5258B	0-2533	705	8607	6454	5258B	0-2443	705	8602
6320	5258B	0-2799	705	8600	6455	5258B	0-2443	705	8602
6321	5258B	0-2799	705	8600	6456	5258B	0-2798	705	8600
6322	5258B	0-2445	705	8602	6457	5258B	0-2798	705	8600
6324	5258B	0-2799	705	8600	6459	5258B	0-2443	705	8602
6339	5258B	0-2533	705	8607	6460	5258B	0-2443	705	8602
6340	5258B	0-2533	705	8607	6461	5258B	0-2443	705	8602
6341	5258B	0-2799	705	8600	6462	5258B	0-2798	705	8600

# REPLACEMENT FUEL BOWL

CARB#	KIT#	TB#	FLOAT#	PART #	CARB#	KIT#	TB#	FLOAT#	PART #
6463	5258B	0-2443	705	8602	9073	5320B	0-2867	705	8606
6488	5258B	0-2443	705	8602	9074	5320B	0-2869	705	8604
6489	5258B	0-2443	705	8602	9076	5320B	0-2866	705	8612
6496	5258B	0-2443	705	8602	9077	5320B	0-2868	705	8601
6503	5258B	0-2798	705	8600	9078	5320B	0-2869	705	8604
6518	5258B	0-2799	705	8600	9080	5320B	0-2869	705	8604
6545	5258B	0-2798	705	8600	9081	5320B	0-2867	705	8606
6550	5258B	0-2799	705	8600	9085	5258B	0-2533	705	8607
6551	5258B	0-2444	705	8602	9091	5258B	0-2533	705	8607
6568	5258B	0-2533	705	8607	9092	5258B	0-2533	705	8607
6590	5258B	0-2799	705	8600	9093	5320B	0-2870	705	8610
6591	5258B	0-2799	705	8600	9094	5320B	0-2867	705	8606
6592	5258B	0-2444	705	8602	9095	5320B	0-2867	705	8606
6614	5258B	0-2443	705	8602	9096	5258B	0-2448	705	8602
6615	5258B	0-2443	705	8602	9097	5320B	0-2868	705	8601
6616	5258B	0-2443	705	8602	9099	5320B	0-2867	705	8606
9000	5258B	0-2533	705	8607	9100	5320B	0-2867	705	8606
9002	5320B	0-2867	705	8606	9101	5320B	0-2867	705	8606
9004	5320B	0-2867	705	8606	9103	5320B	0-2868	705	8601
9008	5320B	0-2869	705	8604	9104	5320B	0-2801	705	8609
9009	5320B	0-2869	705	8604	9108	5320B	0-2802	705	8600
9010	5320B	0-2869	705	8604	9109	5320B	0-2888	705	8603
9011	5320B	0-2867	705	8606	9110	5320B	0-2867	705	8606
9012	5320B	0-2867	705	8606	9111	5320B	0-2888	705	8603
9013	5258B	0-2433	705	8602	9112	5320B	0-2888	705	8603
9014	5258B	0-2443	705	8602	9114	5320B	0-2869	705	8604
9015	5258B	0-2798	705	8600	9115	5320B	0-2866	705	8612
9016	5258B	0-2443	705	8602	9116	5320B	0-2867	705	8606
9017	5258B	0-2443	705	8602	9117	5320B	0-2625	705	8602
9019	5258B	0-2443	705	8602	9118	5320B	0-2802	705	8600
9020	5258B	0-2433	705	8602	9119	5320B	0-2867	705	8606
9021	5258B	0-2443	705	8602	9123	5320B	0-2616	705	8608
9022	5258B	0-2443	705	8602	9124	5320B	0-2616	705	8608
9023	5258B	0-2443	705	8602	9125	5320B	0-2616	705	8608
9024	5258B	0-2443	705	8602	9126	5320B	0-2616	705	8608
9025	5258B	0-2443	705	8602	9127	5320B	0-2869	705	8604
9027	5258B	0-2798	705	8600	9128	5320B	0-2599	705	8600
9028	5258B	0-2798	705	8600	9134	5320B	0-2597	705	8611
9034	5258B	0-2798	705	8600	9136	5320B	0-2800	705	8607
9035	5258B	0-2448	705	8602	9137	5320B	0-2616	705	8608
9036	5258B	0-2448	705	8602	9139	5320B	0-2867	705	8606
9046	5320B	0-2867	705	8606	9140	5320B	0-2640	705	8608
9049	5258B	0-2443	705	8602	9141	5258B	0-2533	705	8607
9050	5320B	0-2867	705	8606	9142	5258B	0-2533	705	8607
9051	5320B	0-2867	705	8606	9143	5258B	0-2533	705	8607
9053	5320B	0-2869	705	8604	9144	5258B	0-2533	705	8607
9054	5320B	0-2867	705	8606	9145	5258B	0-2533	705	8607
9055	5320B	0-2866	705	8612	9146	5258B	0-2533	705	8607
9056	5320B	0-2867	705	8606	9147	5320B	0-2616	705	8608
9057	5320B	0-2869	705	8604	9149	5320B	0-2867	705	8606
9058	5320B	0-2867	705	8606	9150	5320B	0-2625	705	8602
9059	5320B	0-2867	705	8606	9151	5320B	0-2802	705	8600
9062	5320B	0-2869	705	8604	9152	5320B	0-2616	705	8608
9063	5320B	0-2867	705	8606	9153	5320B	0-2597	705	8611
9064	5320B	0-2868	705	8601	9154	5320B	0-2867	705	8606
9065	5320B	0-2868	705	8601	9160	5320B	0-2867	705	8608
9068	5320B	0-2867	705	8606	9161	5320B	0-2888	705	8603
9069	5320B	0-2867	705	8606	9167	5320B	0-2616	705	8608
9071	5258B	0-2533	705	8607	9173	5320B	0-2802	705	8600
9072	5320B	0-2867	705	8606	9180	5320B	0-2888	705	8603

# REPLACEMENT FUEL BOWL

CARB#	KIT#	TB#	FLOAT#	PART #	CARB#	KIT#	TB#	FLOAT#	PART #
9182	5320B	0-2640	705	8608	9275	5320B	0-2797	705	8608
9183	5320B	0-2616	705	8608	9276	5320B	0-2797	705	8608
9185	5320B	0-2616	705	8608	9277	5320B	0-2797	705	8608
9187	5320B	0-2616	705	8608	9278	5320B	0-2797	705	8608
9188	5320B	0-2802	705	8600	9279	5320B	0-2640	705	8608
9193	5320B	0-2616	705	8608	9280	5320B	0-2796	705	8602
9194	5320B	0-2616	705	8608	9281	5320B	0-2796	705	8602
9195	5320B	0-2640	705	8608	9283	5320B	0-2792	705	8611
9196	5320B	0-2740	705	8611	9284	5320B	0-2640	705	8608
9197	5320B	0-2740	705	8611	9288	5320B	0-2616	705	8608
9198	5320B	0-2740	705	8611	9292	5320B	0-2796	705	8602
9202	5320B	0-2740	705	8611	9293	5320B	0-2792	705	8611
9203	5320B	0-2803	705	8607	9296	5320B	0-2792	705	8611
9205	5320B	0-2803	705	8607	9298	5320B	0-2803	705	8607
9207	5320B	0-2797	705	8608	9299	5320B	0-2803	705	8607
9208	5320B	0-2797	705	8608	9300	5320B	0-2796	705	8602
9209	5320B	0-2797	705	8608	9304	5320B	0-2888	705	8603
9210	5320B	0-2797	705	8608	9305	5320B	0-2791	705	8611
9211	5320B	0-2625	705	8602	9306	5320B	0-2640	705	8608
9212	5320B	0-2625	705	8602	9311	5320B	0-2792	705	8611
9214	5320B	0-2625	705	8602	9313	5320B	0-2804	705	8609
9215	5320B	0-2616	705	8608	9314	5320B	0-2804	705	8609
9216	5320B	0-2616	705	8608	9320	5320B	0-2792	705	8611
9217	5320B	0-2616	705	8608	9321	5258B	0-2533	705	8607
9218	5320B	0-2616	705	8608	9322	5258B	0-2533	705	8607
9219	5320B	0-2616	705	8608	9325	5320B	0-2616	705	8608
9221	5320B	0-2802	705	8600	9326	5320B	0-2804	705	8609
9223	5320B	0-2616	705	8608	9329	5320B	0-2792	705	8611
9224	5320B	0-2597	705	8611	9330	5320B	0-2792	705	8611
9225	5320B	0-2597	705	8611	9331	5320B	0-2792	705	8611
9226	5320B	0-2593	705	8605	9333	5258B	0-2533	705	8607
9227	5320B	0-2616	705	8608	9335	5258B	0-2533	705	8607
9228	5320B	0-2640	705	8608	9336	5258B	0-2533	705	8607
9229	5320B	0-2640	705	8608	9340	5320B	0-2888	705	8603
9234	5320B	0-2792	705	8611	9341	5320B	0-2792	705	8611
9236	5320B	0-2640	705	8608	9342	5320B	0-2792	705	8611
9238	5320B	0-2888	705	8603	9346	5320B	0-2792	705	8611
9240	5320B	0-2802	705	8600	9357	5320B	0-2640	705	8608
9241	5320B	0-2802	705	8600	9358	5320B	0-2796	705	8602
9243	5320B	0-2640	705	8608	9359	5320B	0-2796	705	8602
9244	5320B	0-2791	705	8611	9364	5320B	0-2640	705	8608
9245	5320B	0-2640	705	8608	9365	5320B	0-2792	705	8611
9247	5320B	0-2796	705	8602	9366	5320B	0-2804	705	8609
9248	5320B	0-2796	705	8602	9367	5320B	0-2792	705	8611
9250	5320B	0-2740	705	8611	9368	5320B	0-2792	705	8611
9251	5320B	0-2792	705	8611	9369	5320B	0-2792	705	8611
9252	5320B	0-2792	705	8611	9370	5320B	0-2796	705	8602
9254	5320B	0-2792	705	8611	9371	5320B	0-2640	705	8608
9255	5320B	0-2593	705	8605	9372	5320B	0-2792	705	8611
9256	5320B	0-2616	705	8608	9373	5320B	0-2792	705	8611
9261	5320B	0-2796	705	8602	9374	5320B	0-2792	705	8611
9265	5320B	0-2803	705	8607	9375	5320B	0-2640	705	8608
9267	5320B	0-2640	705	8608	9376	5320B	0-2796	705	8602
9268	5320B	0-2791	705	8611	9377	5320B	0-2829	705	8608
9269	5320B	0-2640	705	8608	9379	5320B	0-2829	705	8608
9270	5320B	0-2616	705	8608	9380	5320B	0-2802	705	8600
9271	5320B	0-2616	705	8608	9382	5258B	0-2533	705	8607
9272	5320B	0-2597	705	8611	9383	5258B	0-2533	705	8607
9273	5320B	0-2593	705	8605	9385	5320B	0-2792	705	8611
9274	5320B	0-2616	705	8608	9388	5320B	0-2792	705	8611